



INSIGHT.DATA.CLARITY.

2024 Annual Report on Engagement

Contents

GLOSSARY OF TERMS..... 2

Introduction..... 3

Proxy voting 3

Activity 4

 1. Overview..... 4

 2. Detailed breakdown..... 5

 Management proposals..... 5

 Shareholder proposals 6

 Deviations from voting guidelines 7

Proxy advisors..... 7

Conflicts of interest 7

GLOSSARY OF TERMS

CFM or the Firm	Collectively, the Capital Fund Management group of companies
Client	A fund, mandate or account managed or advised by a CFM entity, where CFM has authority to vote proxies.
ESG	Environmental, Social and Governance factors refers to three families of factors, scores or criteria, depending on the context, used to evaluate companies' behavior and impact in relation to their significant stakeholders and efforts with sustainability.

Introduction

CFM acknowledges that positioning, voting and engaging activities may produce a societal impact, however small. In accordance with its duty to act in the best interests of its Clients and its adherence to the Principles for Responsible Investment, the Firm is committed to integrating material ESG criteria in its investment processes with a view to enhance returns and/or mitigate risks. CFM believes that, if proper attention is paid to core and dynamic financial materiality, ESG integration is not a distraction, rather a compass to be used alongside its mandate to seek solid risk adjusted performance, as markets are more and more aware of the increasing probabilities that externalities will one way or another, over time, find their way into the price discovery mechanism.

This report covers our voting and engagement activities during 2024. It sets out key figures and commentary on these activities.

This report has been written in accordance with the requirements of Directive (EU) 2017/828 and its implementing measures (together, the “Shareholder Rights Directive II”). The Shareholder Rights Directive II technically only applies to issuers based in the EU or listed in the EU, we have, however, for completeness also included in this report voting activity related to issuers based outside the EU.

Proxy voting

CFM votes by proxy in all shareholder meetings that it is notified of, using a third-party proxy voting adviser (the “Proxy Agent”), except when Clients’ holdings in an issuer are immaterial. CFM will generally vote by proxy in line with recommendations of the Proxy Agent. To this end, CFM has subscribed to the Proxy Agent’s ESG Guidelines and has verified, based on general guidelines and principles, that it rather systematically supports shareholder motions that demand more transparency from companies in terms of strategy for climate change and handling of related risks, in terms of lobbying money being spent on climate change related initiatives, and in terms of linking management remuneration to achieving ESG related targets. For position above a certain size, for ballots relating to particularly sensitive topics, CFM will furthermore from time to time verify that the Proxy Agent’s recommendation fits its Clients’ best interest.

Workflow

- ▶ The Proxy Agent receives daily data on the long positions where Clients have title interest and that may thus be voted for proxies;
- ▶ The Proxy Agent identifies, where the Clients have a material position, the general meetings and the issues that may be voted and issues voting recommendations;
- ▶ Having opted for the ESG service of the Proxy Agent, the Firm also receives ESG based recommendations;
- ▶ CFM checks that certain of the ESG based proxy voting recommendations are in line with the Firm’s ESG convictions. Such recommendations are checked manually on a monthly basis and are modified in line with the Firm’s ESG convictions if required; and
- ▶ Except for any issues identified in the previous step, the Firm votes proxies in line with the recommendations of the Proxy Agent;

This workflow is summarized by the diagram below:

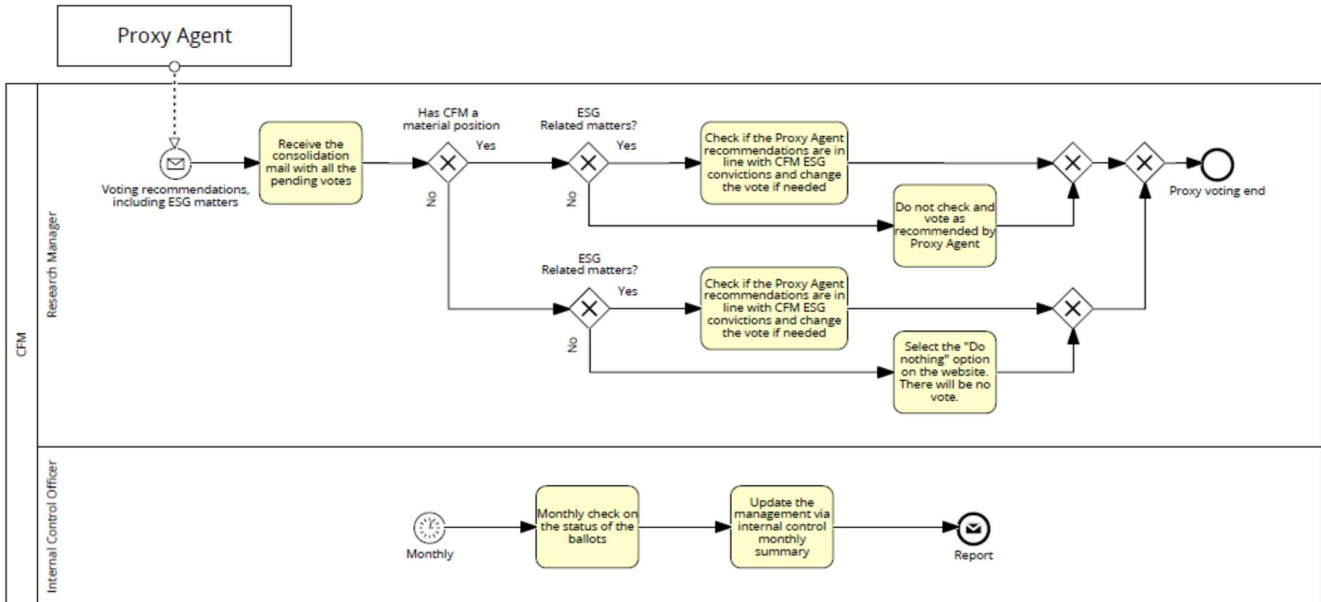

Activity

1. Overview

In 2024, CFM funds voted for 593 meetings out of a total of 955. This represents 2,231 ballots in total.

On these ballots:

- ▶ CFM funds voted 1,709 ballots (73 per cent);
- ▶ CFM funds did not vote for 622 ballots (27 per cent).

From 1/1/2024 to 12/31/2024

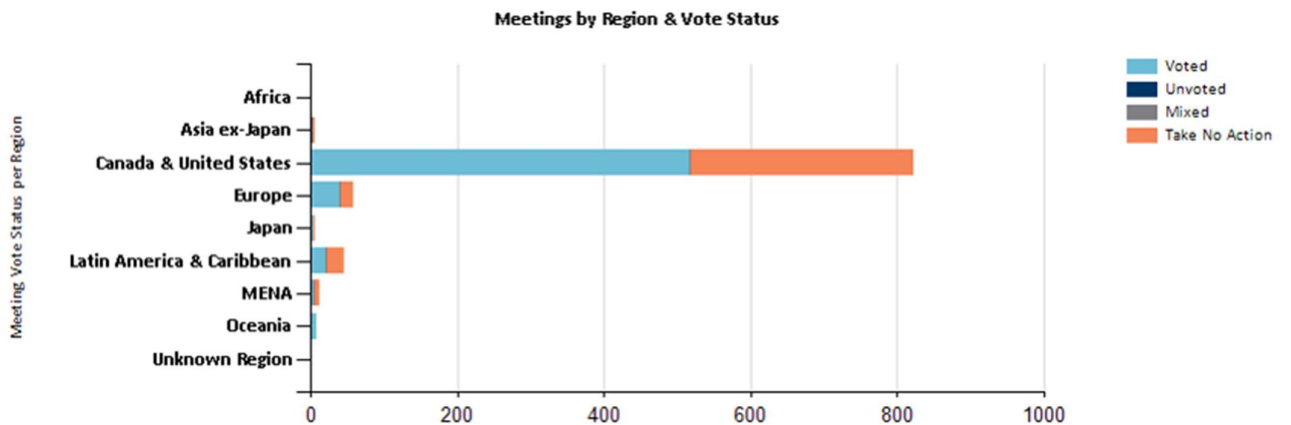

The higher number of meetings for issuers based in North America compared with issuers based in other regions stems primarily from exposures to issuers outside North America being through instruments that do not grant voting rights at meetings.

Meetings with the status “take no action” are events where Clients’ holdings in an issuer were immaterial and thus not voted. Mixed meetings are those with multiple agendas and /or multiple jurisdictions (parent company vs sub) for which one agenda is voted and the other is not.

2. Detailed breakdown

Management proposals

Of a total of 10,119 management proposals, we voted against management on 1,749 items (17 per cent) and supported management on 4,674 items (46 per cent). The funds took no action on 3,696 proposals.

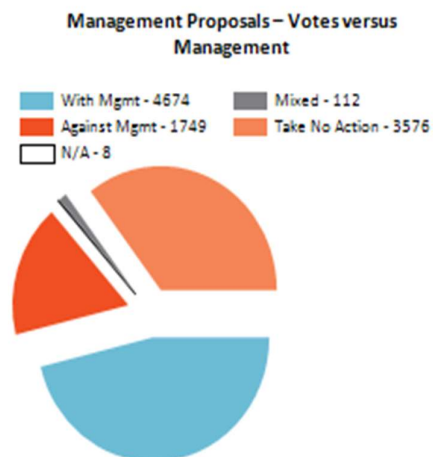

We voted against management on resolutions that related primarily to:

- ▶ Election of Directors (11 per cent),
- ▶ Executive remuneration (3 per cent), and
- ▶ Routine issues such as approval of financials (3 per cent).

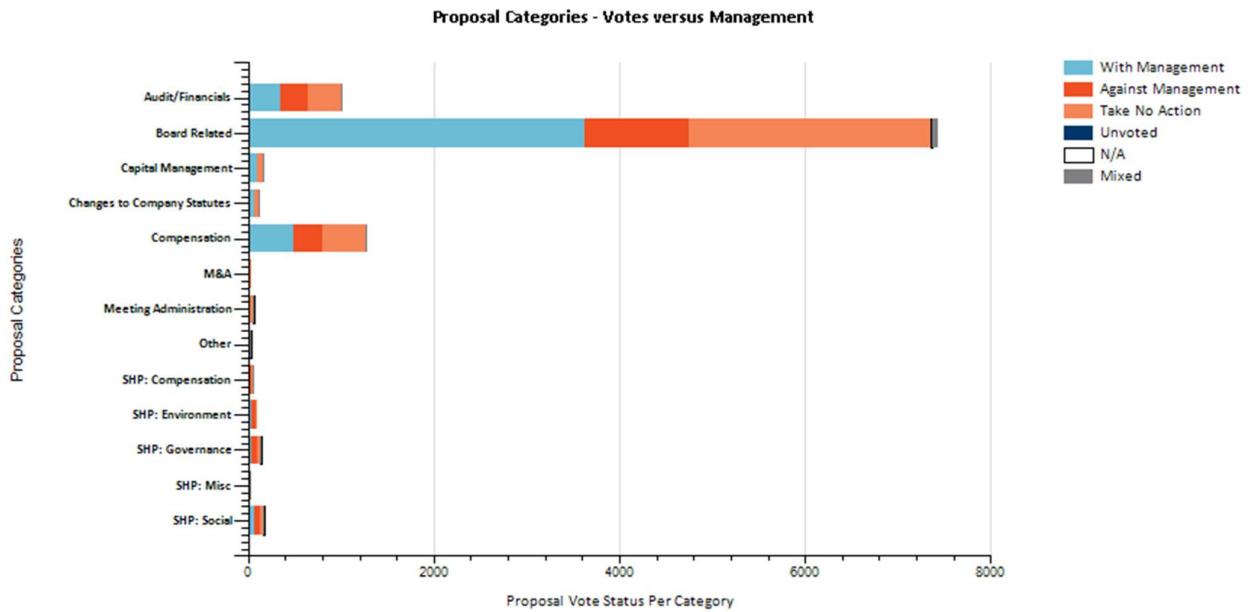

Shareholder proposals

For meetings we participated in, we supported 192 shareholder resolutions out of 456 proposals (42 per cent). The main categories of shareholder resolutions we supported related to social topics such as proposals regarding reviewing political spending or lobbying (14 per cent), governance such as requests for an independent board chairman/separation of Chair and CEO (14 per cent), and other environmental resolutions related for instance to the review of reporting and reducing greenhouse gas emissions (9 per cent).

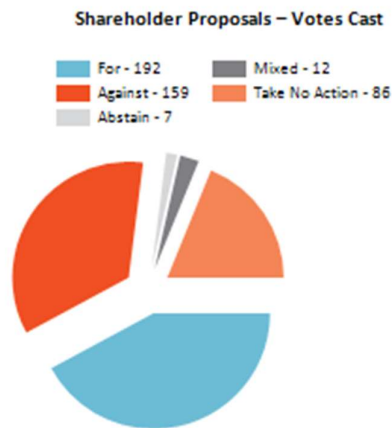

Deviations from voting guidelines

In 2024, we deviated on four occasions from our voting guidelines. For the four deviations, two were related to ESG and for shareholder proposals, one on plastic awareness and the other on lobbying activity related to air traffic and the Paris Agreement.

Proxy advisors

As indicated above, CFM uses a proxy advisor to assess ballots and to exercise voting rights at meetings.

Conflicts of interest

CFM did not identify any conflict of interest during this fiscal year.